

Specification Sheets

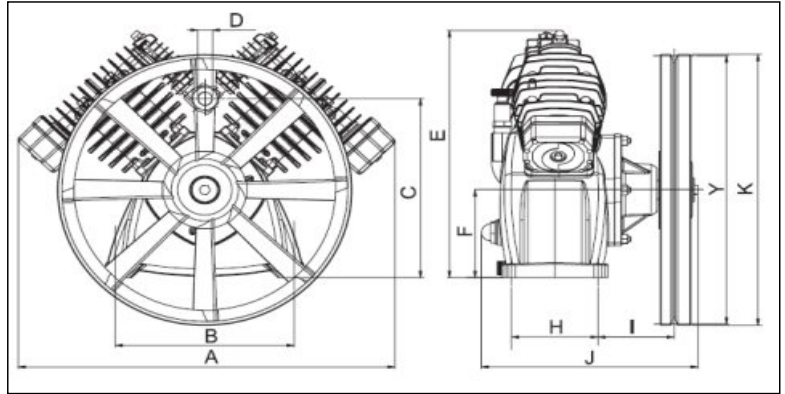

Model: SKM 15 **Code:** AOB-4-5131920000 **Cat. Ref:** AA01

Pump

Model:	SKM 15
Make:	Fini
Country of origin:	China
Motor power (kW):	4.0
Type of control:	Auto Stop Start
Quoted working pressure (kPa):	700
Max working press.(kPa) (4.0kW @ 1250rpm):	1000
Piston displacement (lit./min):	580
Actual delivery (FAD)(lit./min @ 700kPa) :	425
Speed (r.p.m):	1250
Crankcase material:	Cast Iron
Head material:	Aluminium
Number of stages:	1
Number of cylinders:	2
Cylinder arrangement:	Vee
Cylinder material:	Cast Iron
Bore LP(mm):	2 X 70
Stroke (mm):	60
Drive:	Vee drive
No. of Belts:	1
Belt Section:	B
Qty oil fill (lt):	1.3
Dimensions (L.W.H. mm) (No Packing):	514 X 295 X 438
Mass (kg) (No Packing):	23
Approx Dimensions (L.W.H. mm) (Packaged):	440 X 320 X 480
Approx Mass (kg) (Packaged):	24.2

Key Dimensions (mm)

A	514
B	244
C	265
D	R1/2"
E	367
F	130
H	118
I	104
J	295
Y (PCD)	398
K	402

Compressor Flywheel

Outside dia (mm) (1 Vee B Sec)	402
PCD (mm)	398

Motor Drive Pulley

(Closest standard for the nominated speed)

2 Pole 4.0kW 50Hzt Motor	170 x 1SPB
4 Pole 4.0kW 50Hzt Motor	-

Key Parts - Description

Code

Intake Air Filter Element: 1off	CTB-017003000
Valve Kit with Gaskets: 1off	CTA-002-SKM15
Ring Kit with Gaskets: 1off	CTA-003-SKM15
Compressor Oil: 2lt Bottle	KAA-P100-002