

Specification Sheets

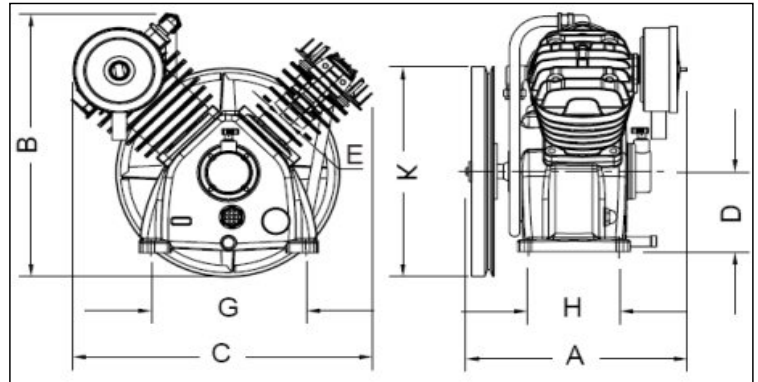
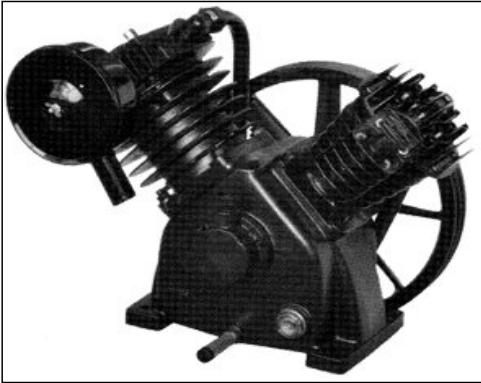

Model: SKB 20 **Code:** AOB-6-5131830000 **Cat. Ref:** AA02

Pump

Model:	SKB 20
Make:	Fini
Country of origin:	China
Motor power (kW):	5.5
Type of control:	Auto Stop Start
Quoted working pressure (kPa):	700
Max working press.(kPa) (5.5kW @ 1115rpm):	1200
Piston displacement (lit./min):	722
Actual delivery (FAD)(lit./min @ 700kPa) :	562
Speed (r.p.m):	1115
Crankcase material:	Cast Iron
Head material:	Cast Iron
Number of stages:	2
Number of cylinders:	2
Cylinder arrangement:	Vee
Cylinder material:	Cast Iron
Bore LP(mm):	1 X 105
Bore HP(mm):	1 X 55
Stroke (mm):	75
Drive:	Vee drive
No. of Belts:	1
Belt Section:	B
Qty oil fill (lt):	1.6
Dimensions (L.W.H. mm) (No Packing):	507 X 373 X 477
Mass (kg) (No Packing):	53
Approx Dimensions (L.W.H. mm) (Packaged):	710 X 470 X 700
Approx Mass (kg) (Packaged):	75.5

Key Dimensions (mm)

A	373
B	477
C	507
D	145
E	R1/2"
G	262
H	155
K (PCD)	394

Compressor Flywheel

Outside dia (mm) (1 Vee B Sec)	403
PCD (mm)	394

Motor Drive Pulley

(Closest standard pulley for the nominated speed)

2 Pole 5.5kW 50Hz Motor	150 x 1SPB
4 Pole 5.5kW 50Hz Motor	280 x 1SPB

Key Parts - Description

Code

Intake Air Filter Element: 1off	CTB-017080000
Valve Kit with Gaskets: 1off	CTA-002-SKB20
Ring Kit with Gaskets: 1off	CTA-003-SKB20
Compressor Oil: 2lt Bottle	KAA-P100-002