

Specification Sheets

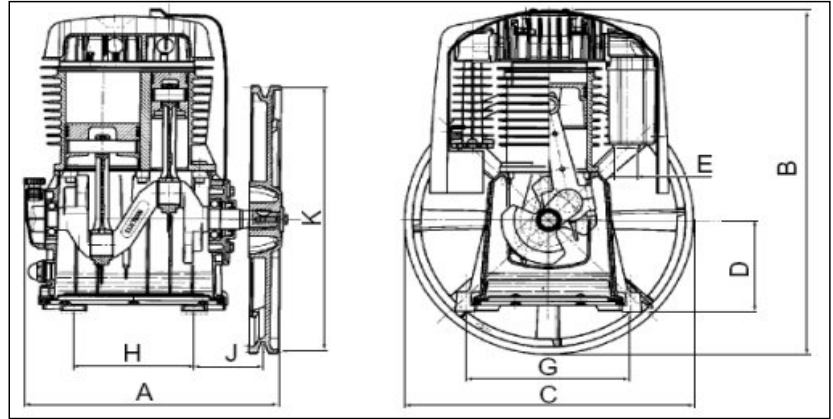

Model: BK119 **Code:** AOB-6-513179000 **Cat. Ref:** AA05

Pump

Model:	BK119
Make:	Fini
Country of origin:	Italy
Motor power (kW):	5.5
Type of control:	Auto Stop Start
Quoted working pressure (kPa):	700
Max working press.(kPa) (5.5kW @ 1215rpm):	1000
Piston displacement (lit./min):	820
Actual delivery (FAD)(lit./min @ 700kPa) :	704
Speed (r.p.m):	1215
Crankcase material:	Aluminium
Head material:	Aluminium
Number of stages:	2
Number of cylinders:	2
Cylinder arrangement:	Vertical
Cylinder material:	Cast Iron
Bore LP(mm):	1 X 105
Bore HP(mm):	1 X 52
Stroke (mm):	78
Drive:	Vee drive
No. of Belts:	1
Belt Section:	Z
Qty oil fill (lt):	1.34
Dimensions (L.W.H. mm) (No Packing):	402 X 356.5 X 517.5
Mass (kg) (No Packing):	26.5
Approx Dimensions (L.W.H. mm) (Packaged):	450 X 400 X 550
Approx Mass (kg) (Packaged):	30

Key Dimensions (mm)

A	356.5
B	517.5
C	402
D	137
E	R3/4"
G	229
H	169
J	95.6
K (PCD)	398

Compressor Flywheel

Outside dia (mm) (1 Vee Z Sec)	402
PCD (mm)	398

Motor Drive Pulley

(Closest standard pulley for the nominated speed)

2 Pole 5.5kW 50Hz Motor	160 x 1SPZ
4 Pole 5.5kW 50Hz Motor	-

Key Parts - Description

Code

Intake Air Filter Element: 1off	CTB-113178013
Valve Kit with Gaskets: 1off	CTA-002-019
Ring Kit with Gaskets: 1off	CTA-003-019
Compressor Oil: 2lt Bottle	KAA-P100-002