

Specification Sheets

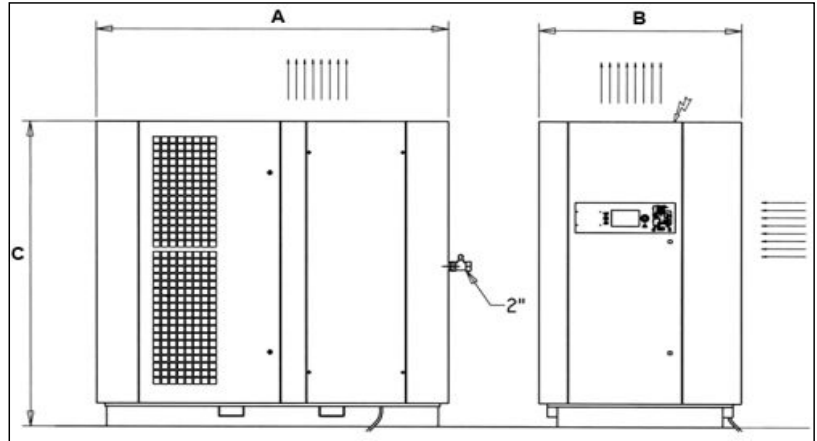

Model: GIGA 10010 **Code:** BBB-10010 **Cat. Ref:** BF02

Compressor Package

Model:	Giga 10010
Make:	Fini
Country of origin:	Italy
Free Air Delivery (lit/min / cfm @ 1000kPa):	10500 / 371
Rated Working Pressure (kPa):	1000
Load / Unload (kPa)	Adjustable
Operation:	Continuous / Stop Start
Noise level (PNEUROP PN8NTC2.2) (dB(A)):	72
Air cooled Aftercooler:	Included
Final air discharge temp above ambient (°C):	11
Max. Ambient temperature (°C):	50
Min. Ambient temperature (°C):	5
Automatic Star Delta Starter:	Included
Max. Oil content in the air at discharge (mg/m³):	4
Drive:	Poly-vee
Air End model:	Tamrock E25
Number of stages:	1
Total Heat removed (kJ/h):	256500
Fan flow rate (m³/h):	8800
Discharge air temp. shutdown (°C):	110
Discharge air temp. warning (°C):	105
Qty oil fill (lt):	37
Qty oil for topping-up (lt):	10
Air outlet connection (bsp):	2"

Dimensions

Dimensions (L.W.H. mm) (No Packing):	2100X 1200 X 1970
Mass (kg) (No Packing):	1940
Approx Dimensions (L.W.H. mm) (Packaged):	2120 X 1220 X 1990
Approx Mass (kg) (Packaged):	1955

Electric Motor

Type:	TEFC
Power (kW):	75
Power (HP):	100
Voltage / Hz / Ph:	400 / 50 / 3
Full load amps:	133
Motor Protection:	IP54
Motor Insulation class:	F
Max. Start-up per hour (n°):	10
Motor Speed:	2 - Pole
Breaker Size:	200 Amps Curve D
Cable Size (under 15m) (mm²):	50

Key Dimensions (mm)

A	2100
B	1200
C	1970

Key Parts - Description

Code

Air Filter:	CTB-017067001
Oil Filter:	CTB-048313000
Oil 5lt:	KBA-ROTENERGY-005L

POSITIONING THE COMPRESSOR

The room chosen for the installation of the compressor should meet the following requirements and comply with currently safety and accident prevention regulations:

- A) **low percentage of dust suspended in air,**
- B) proper room ventilation and size that allow room temperature (5 °C - 50 °C) to be maintained - with the machine running. Minimum air intake opening: 2 sq/m.
- C) in the event of inadequate hot air discharge, fit three or more exhaust fans as high as possible.

Exhaust flow rate "4000 m³/hr" part no. 020042000

- The condensate is a polluting mixture and should not be disposed of into the sewage system or wasted in the environment. The sump should be equipped either with a valve and a removable container or connected to a suitable piece of equipment (oil-water separator, part no. 048203000). Dimensions shown are indicative. It is recommended to comply with given indications.

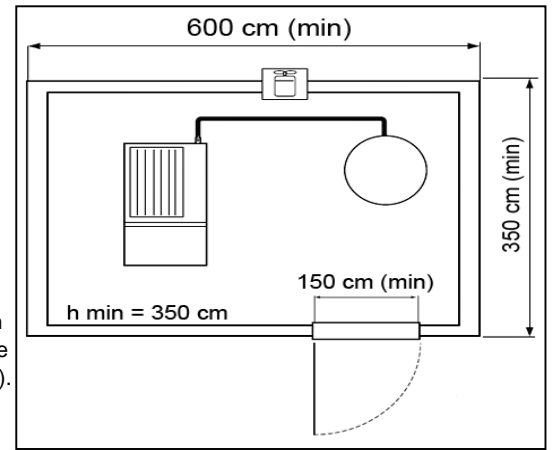

OPERATION

WORKING CYCLE

- **During first start-up**, motor is started and "star" powered. During this phase compressor starts slowly, solenoid valve is closed and suction regulator (2) is closed.
- **The compressor** is kept under these conditions for about 6 seconds
- **This time over**, motor is "delta" powered. The solenoid valve (1) is powered and enables suction regulator (2) opening. The regulator sucks in air through filter (1).
- During this stage compressor is working at peak rpm and starts compressing air inside oil separator tank (5), through tube (4).
- **Compressed air** cannot escape through the minimum pressure valve (7), which is set at 3-4 bar.
- **Compressed air** compresses oil inside the tank (5) and causes it to flow through tube (8) to the radiator (9).
- Cooled oil is returned to filter (11) through tube (10).
- **From filter (11)**, oil reaches compressor (3) through tube (12). Oil mixed with sucked air to form an air/oil mixture that provides sealing and lubrication of compressor moving parts.
- **The air/oil mixture** goes back to tank (5), where air and oil are first separated by centrifugation and then by the oil separator filter (6).
- As a result tank (5) will deliver air only to air radiator (9) through tube (13). Air is then conveyed to mains through a cut-off cock.
- **Minimum pressure valve (7)** serves also as a check valve.
- **Compressor** delivers compressed air to outer air tank.
- **Tank inner pressure** increase until reaching maximum calibration value.
- **Once maximum value is reached**, pressure gauge starts timer and powers off solenoid valve of regulator (2).
- **Regulator (2)** closes and compressor stops compressing and starts idling.
- **Timer** continues counting until reaching set value and, if pressure is unchanged, stops the electric motor. If pressure drops to minimum value set on controller, solenoid valve is powered and opens before timer counting is over.
- **Regulator (2)** opens and compressor operates under normal load, timer is reset.
- **This cycle** is automatically repeated.

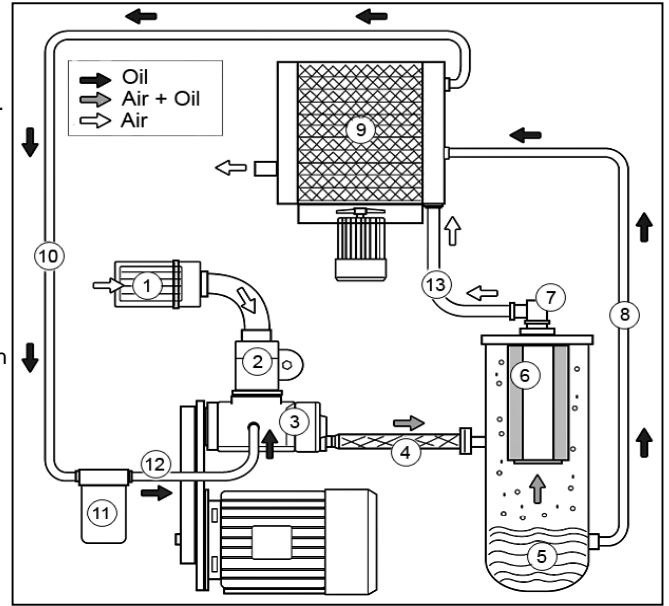

START-UP

Before starting the machine up for the first time, **make sure that:**

- the power supply voltage corresponds to the voltage indicated on the CE plate;
- the electrical connections have been made using adequately sized cables;
- the master switch (on the wall) has suitable fuses;
- the oil level is higher than the minimum (where necessary, fill using oil of the same type);
- the air outlet cock is completely open.

The first start-up of the compressor must only be carried out by a specialised technician.

Press the button:

If the machine does not start and the message "rot.dir.errors" appears on the display:

switch off the electrical power using the wall switch, open the electrical cabinet door and invert the position of two phases in the terminal box, close the door, restore the voltage and restart the machine.

If the machine starts on the first try:

Display status at start-up (remains for 5 seconds)

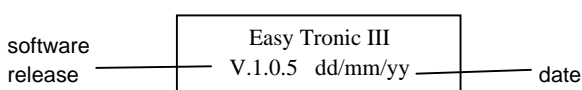

Display status during normal functioning

