

Specification Sheets

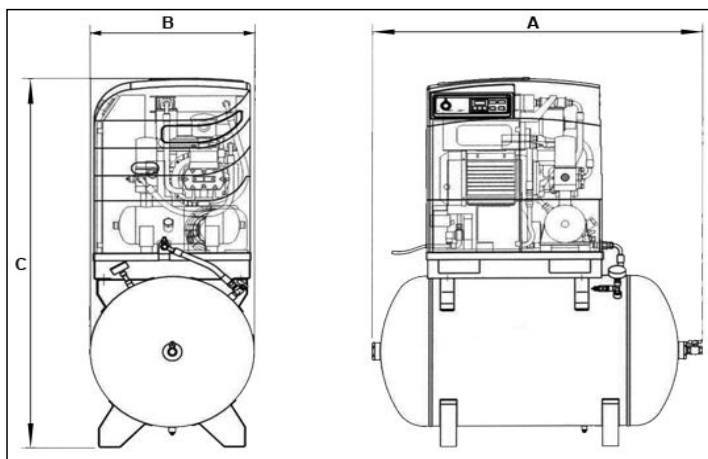

Model: CUBE SD 10-270F TA

Code: BAN-CUBE SD 10-270F-TA

Cat. Ref: BB02

Compressor Package

Model:	CUBE SD 10-270F-TA
Make:	Fini
Country of origin:	Italy
Free Air Delivery (lit/min / cfm @ 800kPa):	1050 / 37.1
Rated Working Pressure (kPa):	1000
Load / Unload (kPa)	Adjustable
Operation:	Continuous / Stop Start
Noise level (PNEUROP PN8NTC2.2) (dB(A)):	67
Air cooled Aftercooler:	Included
Air Dryer:	No
Final air discharge temp above ambient (°C):	20
Max. Ambient temperature (°C):	45
Min. Ambient temperature (°C):	2
Automatic Star Delta Starter:	Included
Max. Oil content in the air at discharge (mg/m³):	4
Drive:	Direct Drive
Air End model:	FS26 TFC
Number of stages:	1
Total Heat removed (kJ/h):	25600
Fan flow rate (m³/h):	1060
Discharge air temp. shutdown (°C):	110
Discharge air temp. warning (°C):	105
Qty oil fill (lt):	3.5
Qty oil for topping-up (lt):	0.5
Air outlet connection (bsp):	1/2"

Electric Motor

Type:	TEFC
Power (kW):	7.5
Power (HP):	10
Voltage / Hz / Ph:	400 / 50 / 3
Full load amps:	15.2
Motor Protection:	IP55
Motor Insulation class:	F
Max. Start-up per hour (n⁰):	10
Motor Speed:	2 - Pole
Breaker Size:	25 Amps Curve D
Cable Size (under 15m) (mm²):	4

Key Dimensions (mm)

A	1300
B	680
C	1650

Key Parts - Description

<u>Description</u>	<u>Code</u>
Air Filter:	CTB-017092000
Oil Filter:	CTB-048495000
Oil 5lt:	KBA-ROTENERGY-005L

Dimensions

Dimensions (L.W.H. mm) (No Packing):	1300 X 680 X 1650
Mass (kg) (No Packing):	217
Approx Dimensions (L.W.H. mm) (Packaged):	1320 X 700 X 185
Approx Mass (kg) (Packaged):	232

POSITIONING THE COMPRESSOR

The room chosen for the installation of the compressor should meet the following requirements and comply with what is specified in the current safety and accident prevention regulations:

- **low percentage of fine dust,**
 - **proper room ventilation and size that allow room temperature under 40 °C.**
- In the event of inadequate hot air discharge, fit the exhaust fans as high as possible.

Exhaust flow rate "2000 m³/hr" part no. 020041000

Exhaust flow rate "4000 m³/hr" part no. 020042000

Condensate should be collected either into a pit or a tank.

The dimensions of the spaces are indicative only but it is advisable follow them as closely as possible.

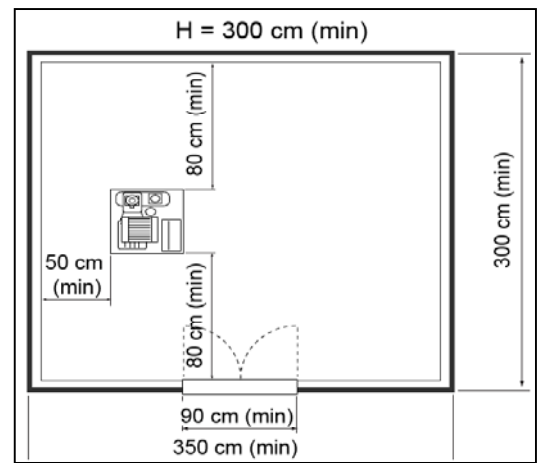

OPERATION

WORKING CYCLE

Cube 5 Direct starting

1) in the first start up the motor starts directly; it reaches standard speed after 5-7 seconds.

Cube 5-7-10 Remote starting

1) At first start up the motor starts in the "star" configuration. In this phase the compressor starts slowly, the solenoid (1) is open, and the suction regulator (2) is closed.

The compressor remains in this condition for about 5-7 seconds, after this time the motor is powered by the "delta" configured circuit.

2) The solenoid valve (1) receives current and closes allowing the opening of the suction regulator (2), which intakes atmospheric air through the filter (3).

3) At this stage, the compressor runs at full speed and begins to compress the air in the tank (6).

4) The compressed air cannot come out from the minimum pressure valve set at 3-4 bar.

5) The compressed air compresses the oil in the tank (6) and forces it to flow through the filter (8) and pipe (7) to the radiator (9).

6) If the oil temperature is below 80 °C the solenoid valve stays still.

7) If the oil temperature exceeds 80 °C the solenoid valve starts operating and cooled oil returns to the compressor through tubes (5).

8) The oil reaches the compressor (4) mixing with the intake air creating an air/oil mixture which ensures the seal and the lubrication of the moving parts of the compressor.

9) The air/oil mixture returns to the tank (6) where the air is pre-separated and later a final separation of the oil take place, through the oil separator filter (10), and finally it is conveyed to the distribution network.

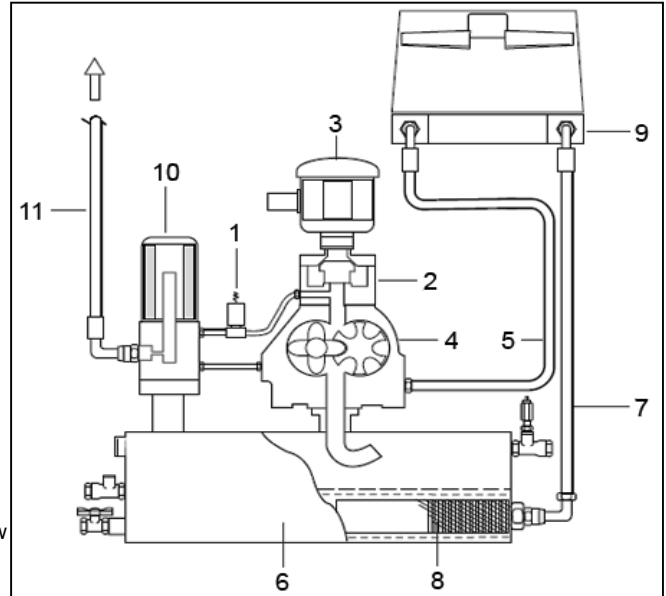

START-UP

FIRST START-UP

Before starting the machine up for the first time, **check that:**

- the mains voltage is the same as the voltage on the CE plate;
- the electric connections have been made using cables of proper cross-section;
- the (wall) main power switch has suitable fuses;
- the oil level is over the minimum level - top up with the same type of oil if necessary;

CONNECT THE TANK WITH A HOSE

Only specialised technicians can start the compressor (on-site testing) for the first time.

The **turning on procedure** starts by pressing the START key (1).

The stand-by led (7) blinks and after a few seconds the presence of the phases and their correct sequences is checked, if the compressor blocks and the warning light turns on the phase sequence device has intervened, press the RESET key (2) and bring the wall switch to OFF position.

Open the electric compartment and invert the position of two phases in the lower terminal box. Close the electrical compartment and restart.

The start up procedure is repeated: the Screw led (6) blinks and after a few seconds it becomes fixed, the load phase starts until the "set loadless pressure" value is reached.

The Screw led (6) blinks again and the loadless operation phase begins.

If at the end of the loadless operation (default 75 sec) the pressure has not fallen below the "set load pressure" value the compressor stops and the stand-by led turns on (7); otherwise upon reaching the "set load pressure" value the compressor restarts the loading phase and the Screw led turns on in fixed mode (6).

During routine operation the following information is displayed on screen:

- pressure,
- temperature,
- total hours of operation (with compressor on),
- hours of operation loaded (with compressor in load phase).

By pressing the RESET key (2) the **turn off procedure** starts, the Screw led (6) blinks and the compressor enters the loadless operation mode for the time set by the parameter "delayed stop time" (default 60 sec). At the end of the cycle the compressor stops.